

SPECIFICATIONS FOR: 50-SBB (BUTCHER BLOCK) FOR RADIUS PEWS

SEATS:

- Solid butcher block construction.
- Selected specie lumber sections 5/4 x 5/4 glued with titebond wood glue.
- Seat is shaped and contoured, finished with a rounded nosing.

BACKS:

- Flat 9-ply laminated back formed to radius.
- Constructed of a 1/2" center core of cabinet grade plywood, 1/8" cross banding of 68 lb. density hardboard both sides, laminated under heated hydraulic pressure with front and back face to be bookmatched selected specie veneer.
- Finished with a 5/4 solid wood cap rail with a tongue and groove joint securely fastened to back, and a solid wood undercap molding.

* W Option – 2" wider back available

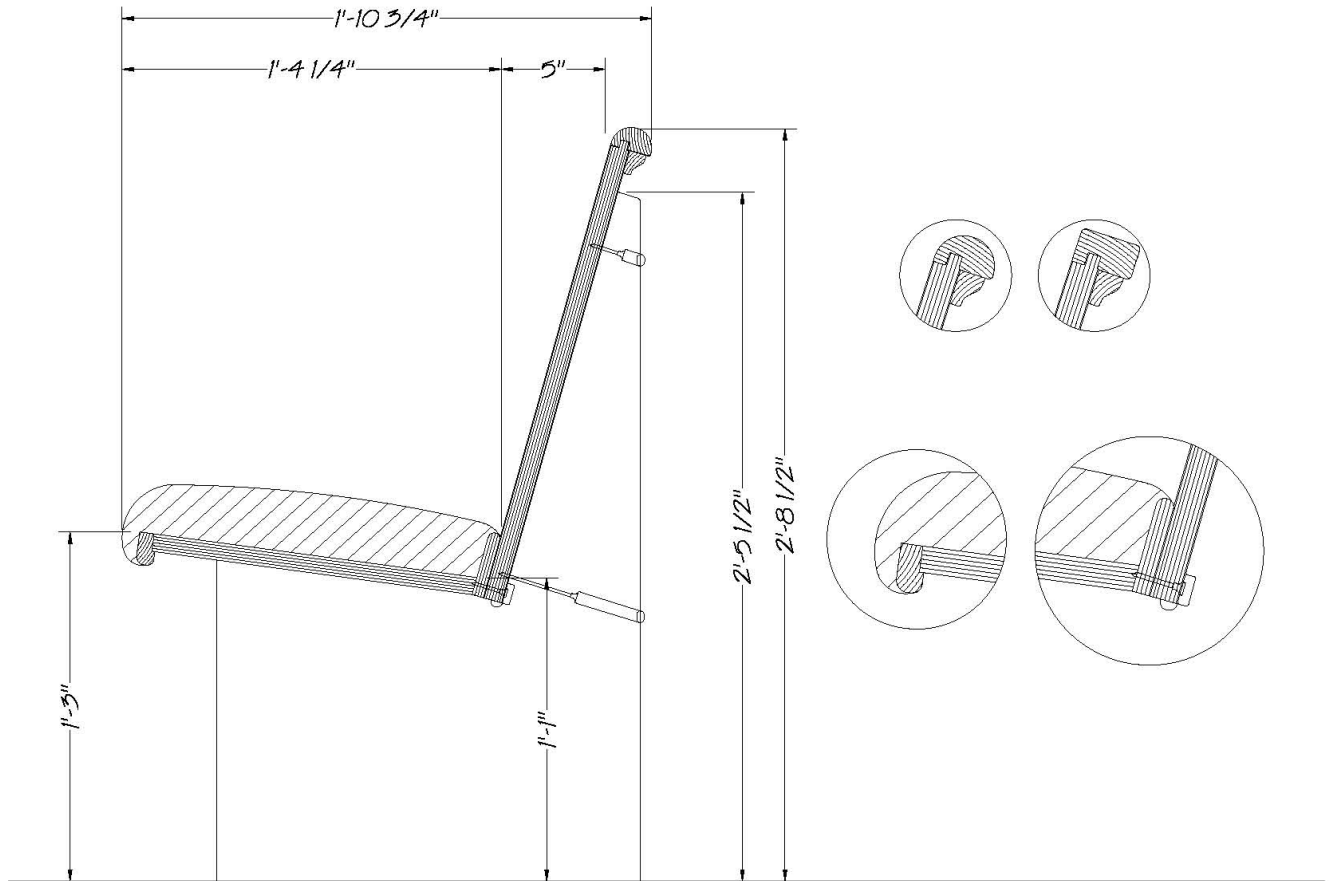

SPECIFICATIONS FOR: 50-US3 RADIUS

SEATS:

- Upholstered foam seat.
- Construction to consist of 3/4" cabinet grade plywood seat foundation cut to radius with solid wood members running horizontally and continuously along front and back edge of seat for maximum strength and stability.
- 3" thick, 1.85 lb. density foam glued to seat foundation.
- Upholstered with choice of fabric. Fabric is tightly stretched using even pneumatic pressure, with edges tucked, folded, and stapled to underseat.

BACKS:

- Flat 9-ply laminated back formed to radius.
- Constructed of a 1/2" center core of cabinet grade plywood, 1/8" cross banding of 68 lb. density hardboard both sides, laminated under heated hydraulic pressure with front and back face to be bookmatched selected specie veneer.
- Finished with a 5/4 solid wood cap rail with a tongue and groove joint securely fastened to back, and a solid wood undercap molding.

* Also available with spring seating system (optional).

* W Option – 2" wider back available

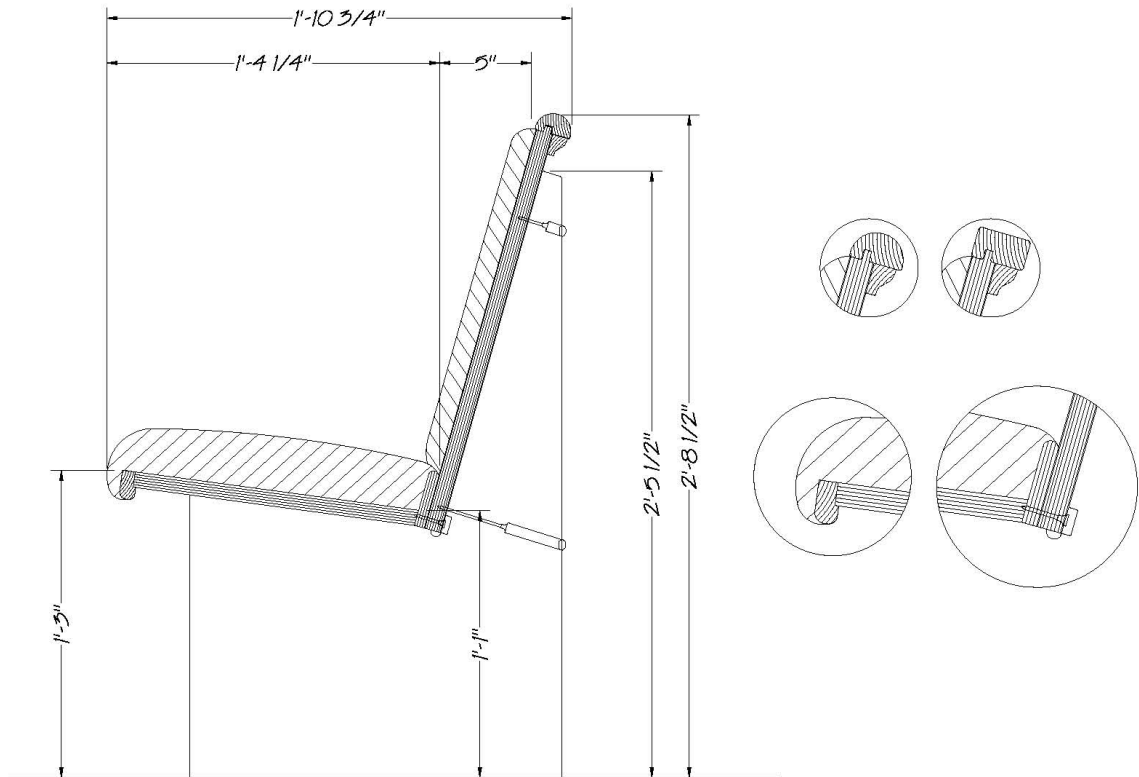

SPECIFICATIONS FOR: 70-US3 RADIUS

SEATS:

- Upholstered foam radius seat.
- Construction to consist of 3/4" cabinet grade plywood foundation cut to radius with solid wood members running horizontally and continuously along front and back edge of seat for maximum strength and stability.
- 3" thick, 1.85 lb. density foam glued to seat foundation.
- Upholstered with choice of fabric. Fabric is tightly stretched using even pneumatic pressure, with edges tucked, folded, and stapled to underseat.

BACKS:

- Upholstered face, veneer backside formed to radius, 9-ply laminated construction using 1/2" center core of cabinet grade plywood, 1/8" cross banding of 68 lb. density hardboard both sides, laminated under heated hydraulic pressure with back face to be bookmatched selected specie veneer.
- Front of back to have 1" foam thickness of 1.5 lb. density.
- Upholstered with choice of fabric. Fabric is tightly stretched using even pneumatic pressure, with edges tucked and stapled to center core.
- Finished with 5/4 solid wood cap rail with a tongue and groove joint securely fastened to back, and a solid wood undercap molding.

* Also available with spring seating system (optional).

* W Option – 2" wider back available

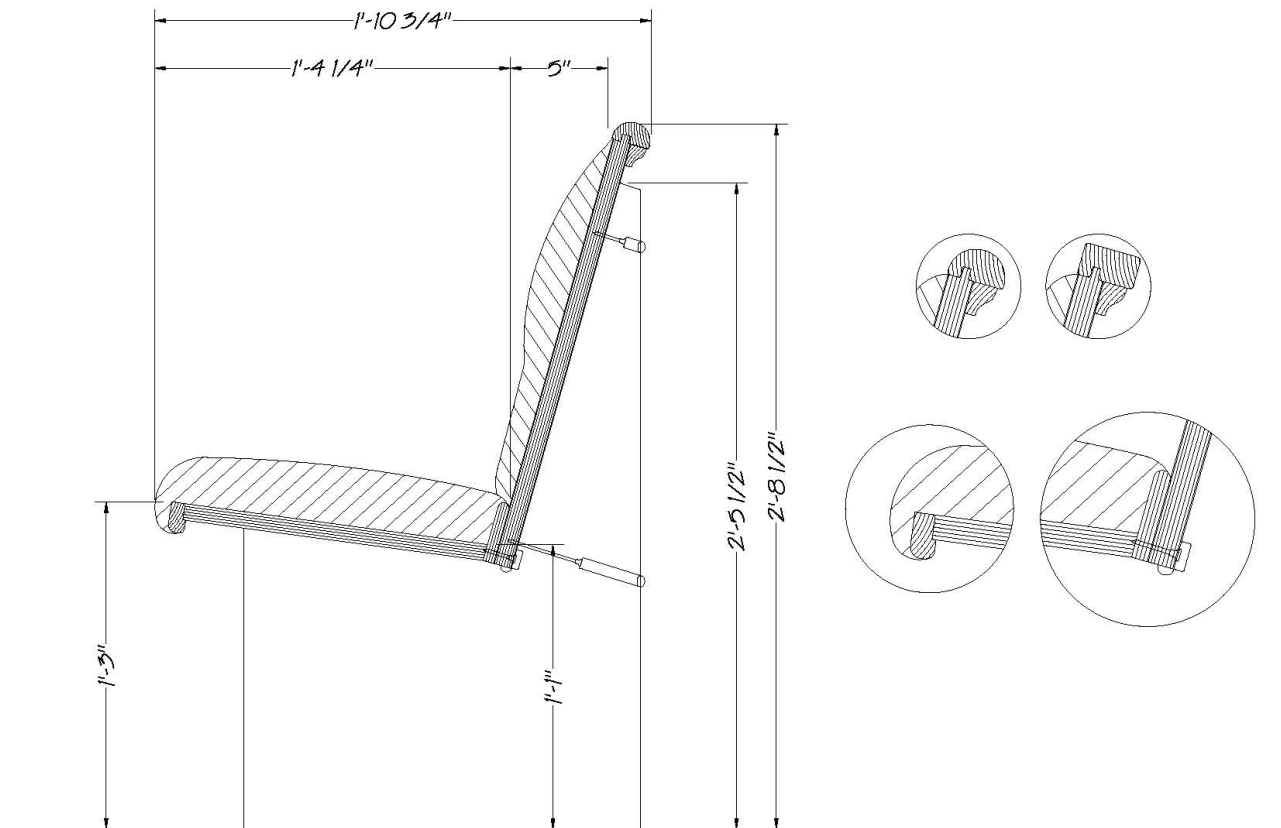

SPECIFICATIONS FOR: 74-US3 RADIUS

SEATS:

- Upholstered foam radius seat.
- Construction to consist of 3/4" cabinet grade plywood foundation cut to radius with solid wood members running horizontally and continuously along front edge of seat for maximum strength and stability.
- 3" thick, 1.85 lb. density foam glued to seat foundation.
- Upholstered with choice of fabric. Fabric is tightly stretched using even pneumatic pressure, with edges tucked, folded, and stapled to underseat.

BACKS:

- Contoured upholstered face, veneer backside formed to radius.
- 9-ply laminated construction using 1/2" center core of cabinet grade plywood, 1/8" cross banding of 68 lb. density hardboard both sides, laminated under heated hydraulic pressure with back face to be bookmatched selected specie veneer.
- Front of back to have contoured foam profile with 1.5 lb. density.
- Upholstered with choice of fabric. Fabric is tightly stretched using even pneumatic pressure, with edges tucked and stapled to center core.
- Finished with a 5/4 solid wood cap rail with a tongue and groove joint securely fastened to back, and a solid wood undercap molding.

* Also available with spring seating system (optional).

* W Option – 2" wider back available

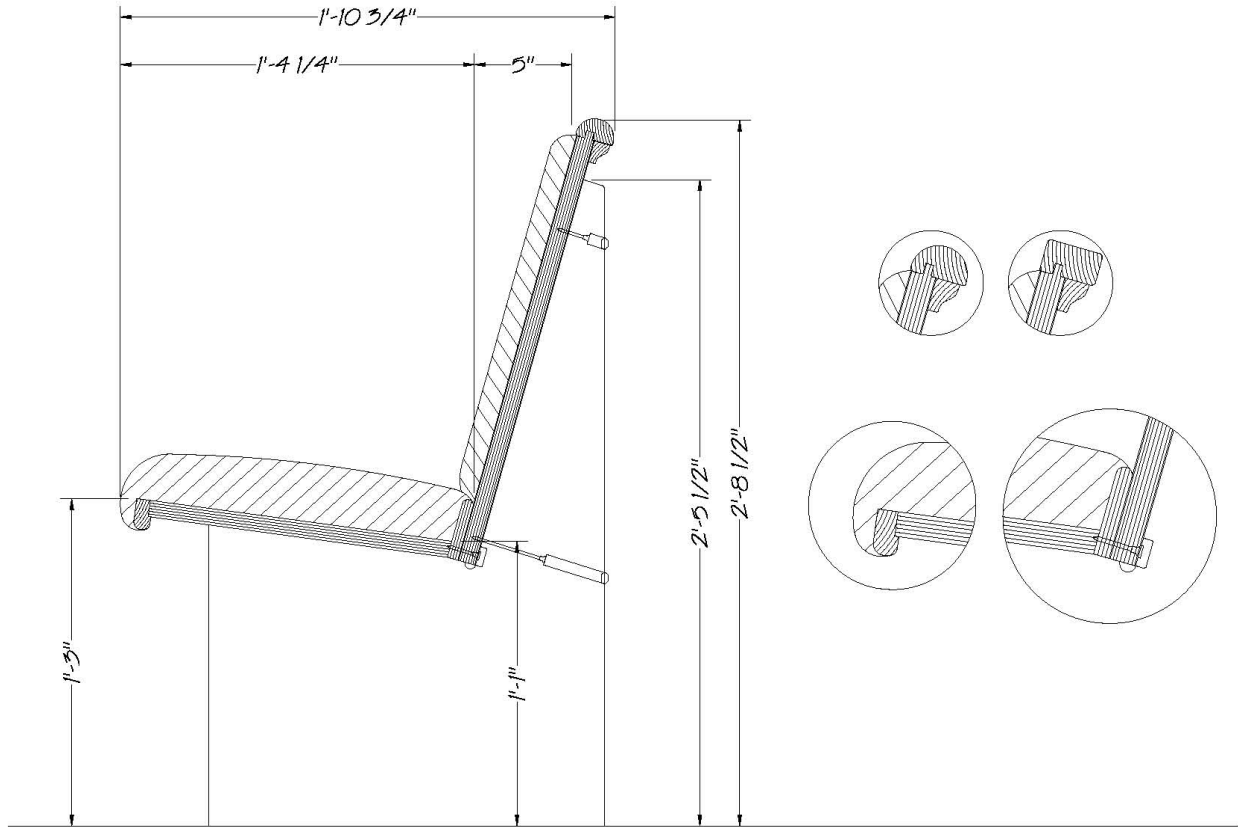

SPECIFICATIONS FOR: 80-US3 RADIUS

SEATS:

- Upholstered foam radius seat.
- Construction to consist of 3/4" cabinet grade plywood foundation cut to radius with solid wood members running horizontally and continuously along front edge of seat for maximum strength and stability.
- 3" thick, 1.85 lb. density foam glued to seat foundation.
- Upholstered with choice of fabric. Fabric is tightly stretched using even pneumatic pressure, with edges tucked, folded, and stapled to underseat.

BACKS:

- Upholstered both sides, formed to radius.
- 9-ply laminated construction using a 1/2" center core of cabinet grade plywood, 1/8" cross banding of 68 lb. density hardboard both sides, and sound, any specie veneers both sides, laminated under heated hydraulic pressure.
- Face side includes a contoured profile foam with 1.5 lb. density.
- Both sides are upholstered with choice of fabric. Fabric is tightly stretched using even pneumatic pressure, with edges tucked and stapled to core.
- Finished with a 5/4 solid wood cap rail with a tongue and groove joint securely fastened to back, and a solid wood undercap molding.

* Also available with spring seating system (optional).

* W Option – 2" wider back available

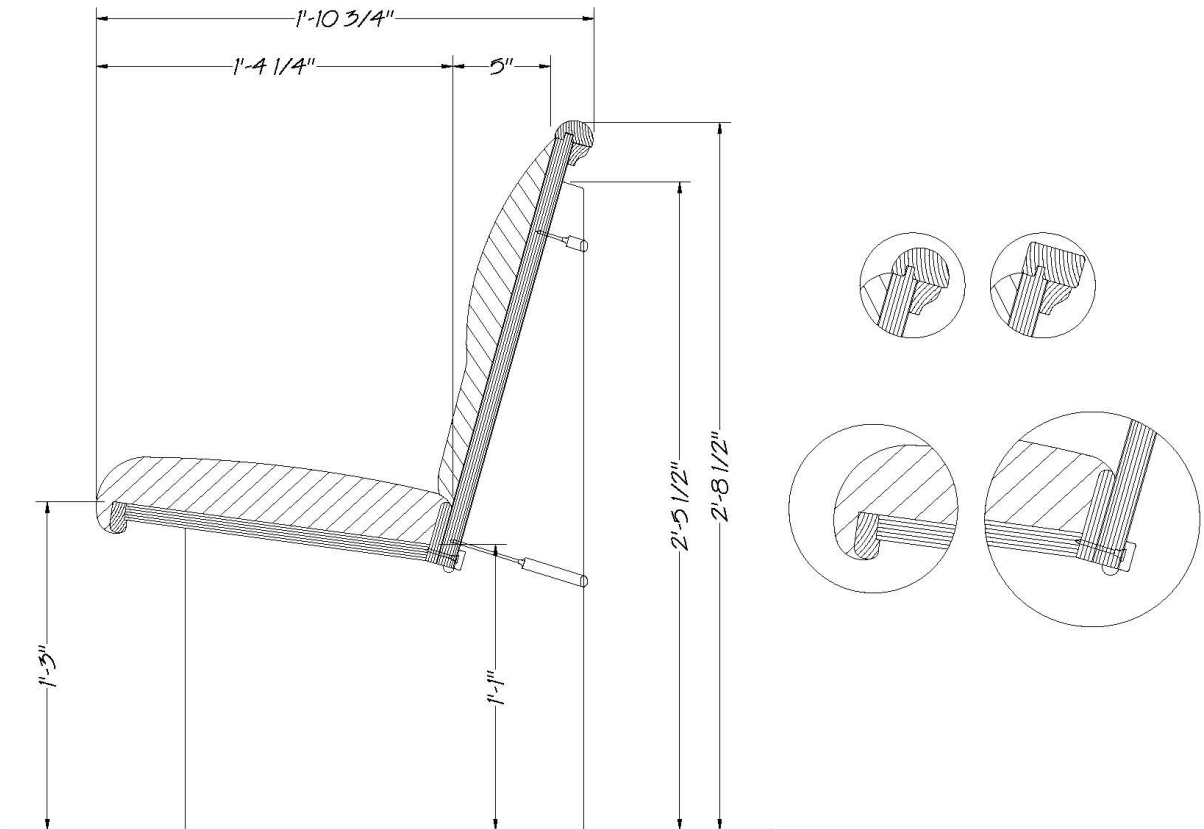

SPECIFICATIONS FOR: 84-US3 RADIUS

SEATS:

- Upholstered foam radius seat.
- Construction to consist of 3/4" cabinet grade plywood foundation cut to radius with solid wood members running horizontally and continuously along front edge of seat for maximum strength and stability.
- 3" thick, 1.85 lb. density foam glued to seat foundation.
- Upholstered with choice of fabric. Fabric is tightly stretched using even pneumatic pressure, with edges tucked, folded, and stapled to underseat.

BACKS:

- Contoured upholstered face, upholstered backside, formed to radius.
- 9-ply laminated construction using 1/2" center core of cabinet grade plywood, 1/8" cross banding of 68 lb. density hardboard both sides, and high pressure cross banding both sides, laminated under heated hydraulic pressure.
- Face side includes a contoured profile foam with 1.5 lb. density.
- Both sides are upholstered with choice of fabric. Fabric is tightly stretched using even pneumatic pressure, with edges tucked and stapled to core.
- Finished with a 5/4 solid wood cap rail with a tongue and groove joint securely fastened to back, and a solid wood undercap molding.

* Also available with spring seating system (optional).

* W Option – 2" wider back available